



**SDX<sup>®</sup> RETRO**  
**2**  
HIGH FLOW SAFETY DRAIN

FOR CONCRETE  
SUBMERGED SUCTION OUTLET FOR SINGLE OR  
MULTIPLE DRAIN USE FOR USE ON WALL OR FLOOR

**OWNER'S MANUAL  
MAINTENANCE & INSTALLATION GUIDE**



VGB Compliant ANSI/APSP/ICC-16 2017 LISTED

**NOTICE**

When installing and using this equipment, basic safety precautions shall always be followed, including the following:

**IMPORTANT SAFETY INSTRUCTIONS.  
To Installers: READ, UNDERSTAND,  
AND FOLLOW ALL INSTRUCTIONS  
AND WARNINGS.**

Give these instructions to the facility owner to keep for future reference. Follow all codes and regulations that apply to the design, installation and use of suction outlet fittings.

**WARNING**

SDX2 and SDX2 Retro must be installed in accordance with Paramount's written instruction manual, and in conformity with applicable Federal, State, Local and Swimming pool industry building and safety codes. Any modification that increases the flow rate of the circulation system shall require reevaluation of the cover/grate and sump to ensure that the flow rating of the Suction Outlet Fitting Assembly (SOFA) is not exceeded.

**DANGER**

PROPER INSTALLATION OF THE SDX2 RETRO IS ESSENTIAL.  
IF YOU HAVE ANY QUESTIONS, PLEASE CALL PARAMOUNT AT  
1.800.621.5886  
OR CONTACT YOUR REGIONAL REPRESENTATIVE.  
PLEASE FOLLOW ALL LOCAL CODES AND POOL SAFETY GUIDELINES.

Certificate of conformity available at  
<https://www.1paramount.com/downloads/manuals/sdx2/SDX2CertificateOfConformity.pdf>

**SAVE THESE INSTRUCTIONS**



8175 W. Buckeye Road. Phoenix, AZ 85043  
Toll Free: 1.800.621.5886 • Phone: 480.893.7607 • Fax: 480.753.3397  
Paramount@1Paramount.com • [www.1Paramount.com](http://www.1Paramount.com)  
US and Foreign patents and patents pending  
see [www.1paramount.com/support/patent-numbers/](http://www.1paramount.com/support/patent-numbers/)

## Signal Words and Symbols Used In This Manual

This Owner's Manual and Installation Guide contains specific precautions and symbols to identify safety-related information. You will find DANGER, CAUTION, WARNING and NOTICE symbols which require special attention. Please read them carefully and follow these precautions as indicated! They will explain how to avoid hazards that may endanger you or persons using or maintaining your pool or spa.

### **DANGER**

DANGER indicates a hazardous situation which, if not avoided, will result in death or serious injury.

### **WARNING**

WARNING indicates a hazardous situation which, if not avoided, could result in death or serious injury.

### **CAUTION**

CAUTION indicates a hazardous situation which, if not avoided, could result in minor or moderate injury.

### **NOTICE**

NOTICE is used to address practices not related to physical injury.

PLEASE REVIEW THE OWNER'S MANUAL AND INSTALLATION GUIDE IN ITS ENTIRETY AND HEED ALL SAFETY INFORMATION. Failure to follow these instructions and warnings can result in DEATH OR SERIOUS INJURY.

## SUCTION ENTRAPMENT HAZARD:

### **DANGER**

• **DEATH or SERIOUS INJURY will result if a drain cover or grate is not installed and used correctly.**

- Pool and spa pumps produce high levels of suction and move high volumes of water, which can cause death or serious injury if a person comes in close proximity to pool or spa drains.
- SOFA shall not be located on seats or the back rests for seats
- Any modification that increases the flow rate of the circulation system shall require reevaluation of the cover/grate and sump to ensure that the flow rating of the Suction Outlet Fitting Assembly (SOFA) is not exceeded.
- Keep clear of pool and spa drains to avoid death or serious injury from suction.

### **DANGER**

**DEATH or SERIOUS INJURY will result from hair entanglement or limb entrapment.**



- Keep clear of pool and spa drains.
- Hair sucked into pool or spa drains will tangle and knot trapping the swimmer underwater. Avoid placing your hair near a pool or spa drain.
- Avoid sitting on pool or spa drains because the suction can cause severe intestinal damage, evisceration, and/or disembowelment.

### **DANGER**

**DEATH or SERIOUS INJURY will result from pool or spa drain covers or grates that are improperly installed, missing, clogged, or broken.**

- Inspect pool and spa before each use to ensure that drain covers and grates are properly in place and secured.
- Ensure that drain covers are not damaged, cracked, broken, loose, clogged, not properly secured, or missing because these conditions increase the chance of death or serious injury from entrapment.
- If a drain cover is discovered damaged, cracked, broken, loose, clogged, not properly secured, or missing, you shall:
  - Close the pool or spa immediately; and,
  - Post a closure notice and keep the pool or spa closed until an appropriate ANSI/APSP/ICC-16 2017 certified drain cover is properly installed.
- Missing, broken, or cracked SOFA component shall be replaced before bathers are allowed to use the pool.
- Loose cover/grates shall be reattached before bathers are allowed to use the pool.

## DANGER



- DEATH or SERIOUS INJURY** will result from contact with a damaged, loose, or missing drain cover.
- Do not allow limbs to contact or be inserted into a drain pipe with a damaged, loose, or missing drain cover. This could result in swelling of the limb and/or trapping a swimmer underwater.
  - Avoid mechanical entrapment of jewelry, swimsuit, hair decorations, finger, toe, or knuckle in a drain pipe with damaged, loose, or missing drain cover. This may result in trapping a swimmer underwater.
- Do not allow body to come into contact with a drain pipe that has a damaged, loose, or missing drain cover. This may result in trapping a swimmer underwater.

## MAINTENANCE INSTRUCTIONS & WARNINGS:

### WARNING

**DEATH or SERIOUS INJURY** can result from pool or spa drain covers or grates that are clogged by debris.

- Any field modification made to a SOFA not authorized by the manufacturer's instructions shall void the SOFA certification.
- No modification shall be made to the SOFA structure or flow path unless the new configuration has been certified as a new SOFA.
- All pool and spa drain covers may become obstructed by debris and should be cleaned periodically due to clogging from debris, such as pieces of plastic, hair, fabric, twigs, leaves, seeds, etc.
- The frequency of periodic cleaning will vary depending on the amount and type of debris introduced into the pool or spa.
- Clogging of the drain cover will increase the suction effect and increase the likelihood of death or serious injury from those hazards listed above.
- A clogged drain can negatively affect the safety of the drain.
- It is advisable to have a qualified pool or spa professional perform this inspection and debris removal from the pool and spa drain covers.
- When servicing the drain cover, the pump connected to the suction must be turned off.
- Do not perform any service of the drain cover in water level above your waist.
- Use drain covers only with a pumping system rated for the corresponding flow or less. Failure to do so can result in hair or body entrapment which can cause death or serious injury. If in doubt about the rating of your system, consult a qualified pool or spa professional.
- Use only the supplied stainless-steel screws with the drain cover. Screws put into the frame anywhere except in the original screw holes will not hold and will allow the drain cover to come off the main drain, causing an entrapment hazard. If a screw hole(s) is stripped, inserts missing, loose, or damaged, consult your owner's manual and installation guide for proper steps to replace, correct, or reattach the compromised drain or drain component.
- The use of adhesives or other attachment methods that prevent access to suction piping or SOFA components requiring periodic service is prohibited.

### WARNING

Suction can pose a serious hazard to swimmers just as electricity can be a hazard. Both are important for proper water filtration and both must be treated with respect. Suction safety begins with a professional design that includes a

quality suction system installed by a certified contractor.

- Certified builders will address the following issues when designing and installing a proper filtration system:
- Properly bond-grounded pumps, time clocks, switches and any other metal in or near water. This is required to address Electrical Shock Hazards.
  - Design the suction piping so there are no single-point suction hazards; single-point suction (one drain) is a leading cause of Body Suction Entrapment Hazards. Note: your certified builder has many effective options for addressing this hazard; they may include dual-drain systems, like MDX-R3, skimmers, gutters, negative edge features and many more products and piping designs known to professionals.
  - Install ANSI/APSP/ICC-16 2017 listed drains, suction covers and debris removal systems. This is the ONLY approved option for preventing Hair Entrapment Hazards, the leading cause of suction related injuries.
  - Design and install an effective circulation system (including optional cleaning systems), to direct filtered water to all areas and interior surfaces. NOTE: Suction fittings can NOT clean or direct filtered water for proper sanitation; that can only be done on the pressure (return) side of the filtration system.

While suction injuries are extremely rare, drowning and diving injuries are far too common and there is little your certified builder can do to eliminate these hazards. You must educate yourself and your guests. Below are some important safety issues every swimmer must know and recognize.

- **PREVENT DROWNING:** Watch children at all times, no swimming alone.
- **NO DIVING IN SHALLOW WATER:** You can be permanently injured.
- **PREVENT SUCTION ENTRAPMENT:** Inspect suction covers before swimming, keep swimmers away from suction fittings, protect long hair, don't swim with loose clothing or large and dangling jewelry.

For more information about the Virginia Graeme Baker Pool and Spa Safety Act, contact the Consumer Product Safety Commission at (301) 504-7908 or visit [www.cpsc.gov](http://www.cpsc.gov).

**WARNING**

Always turn off all power to the pool pump before installing the cover or working on any suction outlet.

- Cover/Grates and all other SOFA components shall be replaced at or before the end of their service life. Service life begins the month and year in which the SOFA is installed with or without water. See parts breakdown at end of this manual for specific component service life notations.
- Any SOFA component that is severely faded, chalking, or brittle when flexed shall be replaced even if it has not reached its indicated service life.
- If the sump/mud ring or any screw receptacle is stripped, cracked or broken that component must be replaced.
- Any SOFA component held in place by the pool finish or concrete substrate that becomes cracked or broken; the material that holds it must be stripped from around the SOFA and new components "mudded" in place. The surface substrate must be free of deterioration and voids.

## ADHERE REPLACE COVER ASSEMBLY STICKER TO THIS PAGE

**Adhere this label to page 4 of the installation manual.  
Must mark year and month of installation**

**Paramount**

8175 W. Buckeye Rd., Phoenix, AZ 85043  
1-800-621-5886 • [1.paramount.com](http://1.paramount.com)

---

**Replace cover assembly within (5) five years.**

**Replace all other components within (25) years.**

SDX2 pool wall & floor drain cover part #005-252-2097-XX  
Maximum GPM = See install manual for complete chart  
Circle year and month of installation.

Year	2021	2022	2023	2024	2025							
Month	01	02	03	04	05	06	07	08	09	10	11	12

System flow rate \_\_\_\_\_

Installed location \_\_\_\_\_

001-025-8822-00 ECN 1996 REV01 PUB 012821  
©2021 Hayward Industries, Inc.

# HOW SDX2 WORKS BETTER

The SDX2 high flow drain system is a dual-drain system designed and tested to safely deliver water to modern high flow pumps.

## Each Drain Addresses All Entrapment Hazards

**Hair Entrapment Avoidance.** At the heart of the patented design is a cover that acts much like sixty self-regulating drains. This is significant because as some of the 'little' drains are covered, excessive suction does not transfer to the remaining openings. When excessive suction is transferred to unblocked openings in a traditional drain grate, the suction causes hair to enter multiple openings, creating a potential entrapment hazard if the hair tangles or puffs up inside the drain, making it impossible to pull free.

**Body Entrapment Avoidance.** The same self-regulating openings that protect against hair entrapment hazards, also provides body entrapment protection. When the self-regulating openings built into the SDX2 cover are combined with it's domed, anti-vortex shape, forming a seal with the cover is difficult.

**Security.** The SDX2 cover is held firmly in place with three recessed security screws which are made from top quality 316 Stainless Steel. And behind the SDX2 cover are at least three more screws to hold the whole assembly in place, providing multiple layers of anti-entrapment protection.

**Durability.** The SDX2 cover and support materials are far more durable than ABS, the typical plastic used in swimming pool drain covers. In addition to fading, the Buna in ABS is prone to UV degradation resulting in structural failures which contribute significantly to suction entrapment hazards.

## Dual-Drain System

**Vacuum Breaker Backup.** As with any dual-drain system, one drain is intended to be a vacuum breaker for the other in the unlikely event a swimmer completely blocks one of the SDX2 drains. In the event of one suction outlet is being completely blocked, the remaining suction outlets is capable of the full flow of the pump(s).

**Dual-Drain Spacing.** Most suction safety codes require dual-drains to be installed three feet apart, pipe to pipe, however some codes require three feet between drain covers. For this reason, Dual SDX2 piping is spaced three (3) feet, ten (10) inches apart. If the drains are located closer than 3 feet, the drains must be located on two different planes (i.e. one on the bottom and one on the vertical wall, or one each on to separate vertical walls), to make it unlikely both drains could be blocked simultaneously.

**Vertical Dual-Drain Installation.** The purpose of the vertical dual-drain installation is to make it less likely two people can approach two drains at once. Effectively, the second drain would be at an individual's feet.

## SDX2 HIGH FLOW SAFETY DRAIN SYSTEM DESIGN



**DANGER**

Check the SDX2 drain cover, fittings and fasteners for damage or tampering before installation and use.

SDX2 is a circulation drain, not intended to remove debris. For this reason it is suggested SDX2 be installed on walls whenever possible. SDX2 is a high flow safety drain system submerged suction outlet suitable for single or multiple drain use on the wall and floor. This is to keep debris and sand from collecting on and around the low velocity SDX2 cover. Do not locate suction outlets on seating areas or on the backrest of such seating areas.



**CAUTION**

Drain covers deteriorate over time due to exposure to

sunlight and pool chemicals and must be replaced every five (5) years from installation (or earlier if the cover or grate becomes damaged in any way).

**NOTICE**

Some covers and grates are incompatible with

other manufacturers' frames and the existing frame must first be removed and a new supplied frame installed.

**WARNING**

The maximum flow rate for each pair of SDX2 drains varies depending on size and orientation of pipe and location on wall or floor. See chart below for flow limits based on variables. Any modification that increases the flow rate of the circulation system shall require reevaluation of the cover/grate and sump to ensure that the flow rating of the Suction Outlet Fitting Assembly (SOFA) is not exceeded. Compliance with this standard requires that these SOFA-configuration specific flow ratings NOT be exceeded at any time the pool is open to bathers. Compliance with this standard requires selecting and installing a SOFA, or combination of SOFAs, such that the resulting individual suction system flow rating is greater than the pumping system's maximum system flow rate.

The velocity at the opening to the SDX2 drain at the system flow is equal to  $\text{gpm}/134.648=(X)\text{FPS}$ . For multiple drain systems where more than two drains are used, the maximum flow rate is calculated per ANSI/APSP-7 Section 4.6 as shown in the following chart.

**SOFA SDX2 FLOW RATINGS**

Flow Rating (GPM)	Pipe Size	Pipe Port Orientation	Drain Mounting Orientation
180	3"	Side	Floor
116	2.5"	Side	Floor
100	2"	Side	Floor
60	1.5"	Side	Floor
178	3"	Bottom	Floor
120	2.5"	Bottom	Floor
100	2"	Bottom	Floor
60	1.5"	Bottom	Floor
140	3"	Side	Wall
108	2.5"	Side	Wall
100	2"	Side	Wall
60	1.5"	Side	Wall
140	3"	Bottom	Wall
108	2.5"	Bottom	Wall
100	2"	Bottom	Wall
60	1.5"	Bottom	Wall

The flow rating for pools with multiple, blockable SOFAs piped together in one body of water without isolation valves shall be determined by combining the flow rating of all SOFAs, minus the flow rating of one. If the flow ratings of all SOFAs are not equal, subtract the flow rating of the SOFA with the highest flow rating.

The flow rating for existing pools with a single, blockable SOFA is the flow rating of the SOFA, when also installed in conjunction with an additional device or system designed to prevent suction entrapment, where the additional device or systems is of a type listed in section 9.4. A single, blockable SOFA in a system that does not also include one of the additional devices or systems shall result in a flow rating of zero.

DESCRIPTION	MAXIMUM SYSTEM FLOW FLOOR	MAXIMUM SYSTEM FLOW WALL	MINIMUM FLOW RATING OF EACH COVER % MAXIMUM SYSTEM FLOW RATE
*One SDX2 High Flow Safety Drain	180 gpm (681 lpm)	140 gpm (529 lpm)	100%
Two SDX2 High Flow Safety Drains	180 gpm (681 lpm)	140 gpm (529 lpm)	100%
Three SDX2 High Flow Safety Drains	360 gpm (1362 lpm)	210 gpm (795 lpm)	66.7%
Four SDX2 High Flow Safety Drains	360 gpm (1362 lpm)	280 gpm (1060 lpm)	50%

\*The addition of an approved SVRS is required when a single SDX2 is being used.

Table derived from ANSI/APSP-7 Section 4.6 Table 1. System flow based on 3" side outlet floor plumbing configuration chart on page 6.

**Pipe size.** To design an efficient suction system in accordance with national swimming pool standards, the following pipe sizing guideline should be followed:

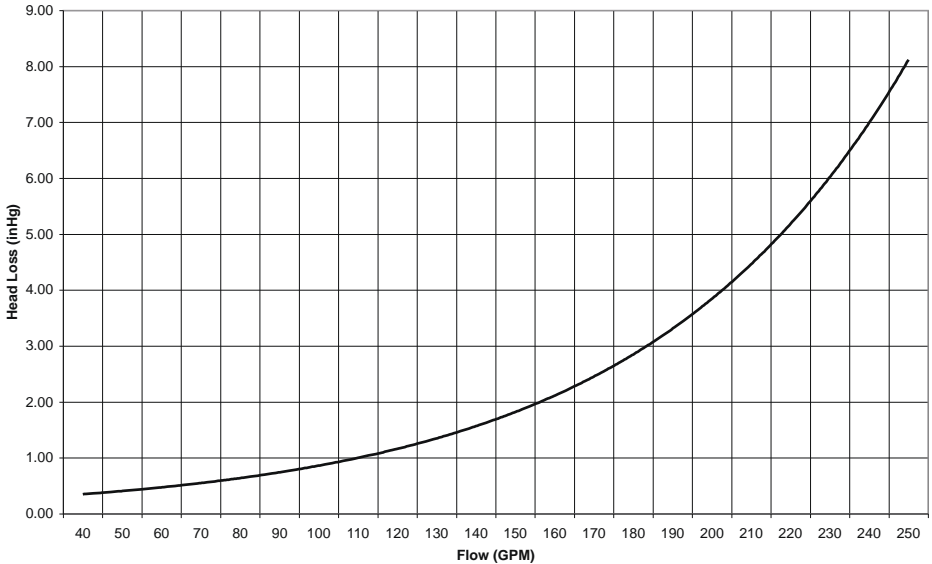
**PIPE SIZE TABLE**

SUCTION PIPE SIZE	MAX RESIDENTIAL GPM	MAX PUBLIC GPM
1½"	50	37
2"	82	62
2½"	117	88
3"	180	136
4"	313 (180 Max gpm)	234 (180 Max gpm)

\*minimum pipe size 1½"

**HEAD LOSS CURVE SDX2**

**Flow vs Head Loss**



SDX2 RETRO is an underwater suction drain cover intended to replace any drain cover up to 10 inches in diameter. SDX2 is approved for single or multiple drain use. When retrofitting a SDX2 to an existing installation with a single suction outlet that is not listed and approved for use as a single suction outlet one of the following must be added in accordance with ANSI/APSP-7

**Excerpt ANSI/APSP-7 Appendix B options for single suction backup:**

**One of these options must be installed on any single suction outlet.**

- Install additional ASME/ANSI A112.19.8 Outlet with the center to center distance between the suction pipes at least 36-inches, or on a separate plane. (see Sections 4.5 & 4.6)
- Convert Suction Outlet to Return Inlet by Changing the piping, provided the system piping and skimmer(s) shall be capable of handling the full system flow.
- Convert to Gravity Flow System in accordance with Section 5.8
- Engineered Vent System in accordance with Section 7.2
- Install & Test. Manufactured Safety Vacuum Release System (SVRS) Tested and Listed for the purpose by a Nationally Recognized Testing Laboratory in accordance with Section 7.1.
- Permanently Disable the Single Outlet, provided the system piping and skimmer(s) shall be capable of handling the full system flow and minimum turnover rates are achieved.

**NOTICE**

The pipe size must be appropriate for the maximum anticipated system flow rate per chart on Page 7. Refer to the table on Page 6 for pipe sizes and orientations.

Your SDX2 RETRO includes five important components; all of components 1-4 below must be used for proper installation. These components are as follows:

1. Drain cover
2. Black drain cover support plate
3. Six black plastic oval slot plugs that must be installed in the drain cover support plate after it is affixed to the pool or spa surface
4. Three 10x7/8 security screws to secure drain cover to drain cover support plate, together with a tool for installing these screws
5. Assorted screws, fasteners, and plastic spacers for attaching drain cover support plate to pool or spa surface. See Installation Instructions to determine which components you will need to use.

1. Turn off all power to pool or spa and pump systems. Installation is easiest when pool or spa is drained.

**CAUTION**

Draining a pool or spa may cause structural damage.

Before draining contact your local licensed pool builder or remodeler.

2. Remove existing drain cover (Fig. 1).
3. Determine from the following choices which provided screws, fasteners, and spacers to use to attach the drain cover support plate to the pool or spa surface.

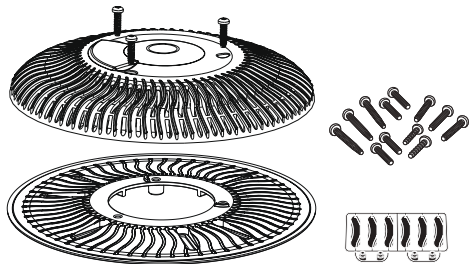
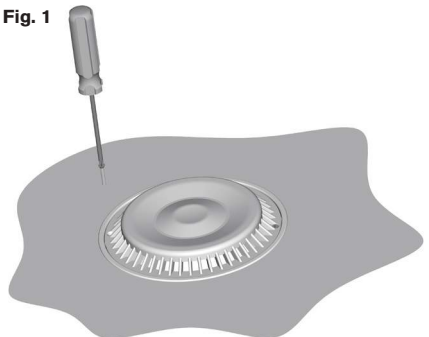


Fig. 1

- 3a. If the pool or spa surface has an embedded ring around the suction pipe, which ring has threaded screw hole inserts, use the provided two 8-32x3/4 screws (Fig. 2). Use the appropriate provided spacers A or B (Fig. 9 pg. 11 small end up) to close the gap between the drain cover support plate and the embedded ring. For example, if you are replacing a







Do not install screws until reading section regarding installing

support plate. Page 10

Pentair drain cover use spacer B.275; if you are replacing a Waterway drain cover use spacer A.250. If you have an AFRAS ABF Series drain (See steps 1-3 on Page 10 for instructions on how to cut screws) then use spacer A.250. Use a knife and cut off small end of the spacer (Fig. 3) and use around the screw between the support plate and embedded ring.

3b. If the pool or spa surface has an embedded ring around the suction pipe, which ring does not have threaded screw hole inserts, or the pool or spa surface has an indented sump without threaded screw hole inserts, and the distance between the pool or spa surface and the tops of the screw holes is shallower than 1/4", use the two provided 10x5/8 self threading screws. No spacers will be needed (Fig. 4).

3c. If the pool or spa has an embedded ring around the suction pipe, which the ring does not have threaded screw hole inserts or has an indented sump without threaded screw hole inserts, and the distance between pool and spa surface and the tops of the screw holes is greater than 1/4" but less than 1/2" use the two provided 10x7/8 self threading screws (Fig. 4). No spacers will be needed.

3d. If the pool or spa surface has an embedded ring around the suction pipe, which ring does not have threaded screw hole inserts, or the pool or spa surface has an indented sump without threaded screw hole inserts, and the distance between pool or spa surface and the tops of the screw holes is deeper than 1/2", use the two provided 10x1-1/4 self-threading screws. No spacers will be needed (Fig. 5).

3e. If the pool or spa surface has no usable holes around the suction pipe that will hold the support plate securely, drill new .160 diameter holes in the plastic ring or drill .250 diameter holes in the concrete and use the plastic anchors to make holes to accept the screws. Then use the correct length #10 self threading screws provided from the instructions above to secure the drain to the pool or spa surface. No spacers will be needed (Fig. 6).

3f. If you have a Jacuzzi MO series drain use the long 10-24 pan hd screw. This screw may need to be cut to fit the application.

### Cutting Screws

1. Install the screw into the support plate and measure the distance between the bottom of the screw head and the notch in the support plate.

Fig. 2

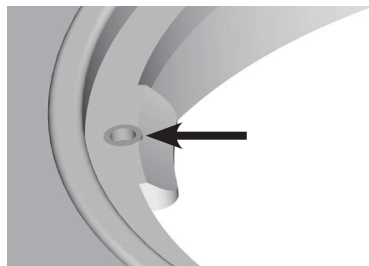


Fig. 3



Fig. 4



Fig. 5



**FAILURE TO USE THE CORRECT SPACERS MAY CAUSE THE POOL COVER SUPPORT PLATE TO BE PULLED FROM THE POOL OR SPA SURFACE.**

If the spacers provided do not properly fill the gap because of pool interior surface level in relation to the sump or embedded ring stop. Do not use the threaded inserts go to method described in step 3E to complete the installation.

2. Remove the screw. Using a screw cutter (typically found in the handle of wire strippers) cut screw to the correct length.
3. Install screw through the support plate into the sump until the support plate is snug to the pool surface and there is no gap behind the support plate.

## Installing Support Plate

### NOTICE

DO NOT USE  
POWER TOOLS  
TO INSTALL

FASTENERS. Start all fasteners by hand to prevent cross threading.

1. Align the drain cover support plate over the ring or sump (Fig 7). If pipe cannot be centered under plate then a 1" deep sump will give optimum water flow to the pump. If the pipe can be relatively centered NO SUMP is required.

### NOTICE

Suction Safety Standards require that main drain concrete sumps, must have the suction pipe cut at least 1 1/2 times the pipe diameter behind the drain cover.

This is to allow room for even water flow through all drain cover holes. This is not necessary with the SDX2 drain because the Patented design provides uniform suction regardless of pipe location. However, if the pipe is too close to the surface and off center, this may restrict water flow to the pump, reducing hydraulic efficiency, but this does not pose a suction safety hazard.

2. SOFA components and fastener receptacles shall be clean and free of debris and obstruction during installation of cover/grate fasteners.
3. Attach the drain cover support plate to the pool or spa surface with the appropriate screws, fasteners, and spacers as described in 3a on Page 9.  
**Completely hand tighten screws to 18 in-lbs. Do not use power tools.**

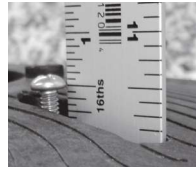
Once installed, be sure that the drain cover support plate is firmly in place and cannot be pulled out of the pool or spa surface. If the drain cover support plate is not firmly in place, re-read these instructions and try another installation method (perhaps 3e) (Fig. 6).

### WARNING

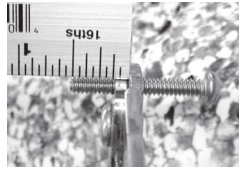
Failure to securely fasten black support plate can result in injury or death.

4. Securely snap all six oval slot plugs provided into the six slots in the drain cover support plate. Use the plugs without tabs (marked C) over screws (tabs may be broken off if necessary). When tabs are broken off the tree the attachment points at each end must be trimmed flush for the part to fit snugly in the support plate.  
**CAUTION: FAILURE TO PROPERLY INSTALL THE PLUGS COULD DISABLE THE SAFETY FEATURES OF THE SDX2 RETRO (Fig. 10).**

### Step 1.



### Step 2.



### Step 3.



Fig. 6



Fig 7

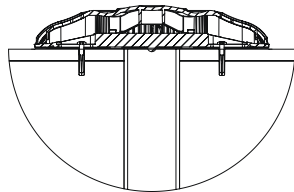
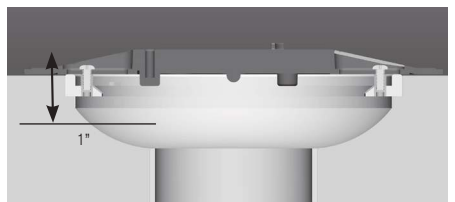


Fig. 8

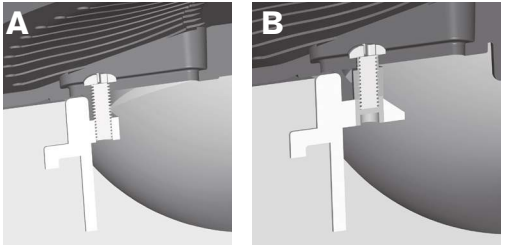


If pipe cannot be centered under plate then a 1" deep sump will give optimum water flow to the pump. If the pipe can be relatively centered NO SUMP is required.

5. Attach the drain cover to the drain cover support plate using the tool and the three 10x7/8 security screws provided (Fig. 11). Paramount requires the use of security screws to secure the cover. **Completely hand tighten screws to 18 in-lbs. Do not use power tools.**

6. If the SDX2 Retro is on a curved wall such as a spa, or the wall/floor of the pool is uneven, then the gap between the back plate of the SDX2 and the pool finish must be filled. An under water epoxy such as AB epoxy putty may be used or if the pool is empty then silicon glue may be used. Allow for drying time in both cases before suction is applied to the drain cover.

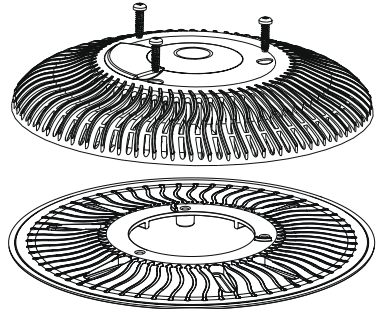
**Fig. 9**  
Attached without spacers and threaded inserts      Attached with both spacers and threaded inserts



**Fig. 10**

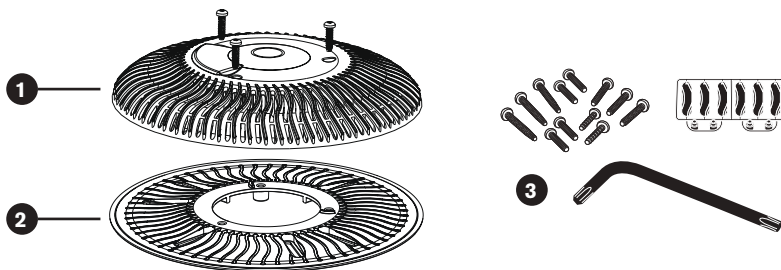


**Fig. 11**



**\*\*Replace cover within 05 installed years**

## SDX2 RETRO CONCRETE PART NUMBERS



Item	Part Number	Description
1**	005-252-2099-XX	SDX2 Retro Cover with screws
2**	005-252-2067-00	SDX2 Retro Support
3**	005-252-0886-00	SDX2 Retro Screw Pack for Concrete Includes: Screws, trim pack, TORX Wrench T-25 Security

Please indicate your color choice by placing the appropriate color code in place of the "XX" at the end of the part number.  
Colors are provided on the inside of the back cover.

White-01    Gray-02    Black-03    Taupe-04    Blue-05    Light Blue-06    Beige-07    Light Gray-08